

M12HT-VENT

Enclosure Anti-Condensation Valve



Key Features

- IP67 Protection (water pressure resistance: 14.5-21 bar/min)
- Permeability: 1000-1500 ml/min
- Temperature Range: -40°C - 125°C
- Screw fixing method



Technical Specifications

Construction Material	PA66 + 25% Glass Fibre	Salt-Fog Resistance	10Hs <0.1%
Gas-Permeable Membrane Material	ePTFE	Antibacterial Grade (GB/T 2423.16)	Level 1
O-Ring Washer Material	Silicone 60H (Shore hardness: A)	Temperature Range	-40°C to +120°C
Lock Nut Material	PA66	Traceability	Y/Laser Sequence No.
Flammability Rating acc. to UL94	V0	Permeability (ml/min.@0.07bar)	350-400
Anti-UV Grade (1000H)	Level 4-5	Membrane Features	Oleophobicity & Hydrophobicity

Parts Identification

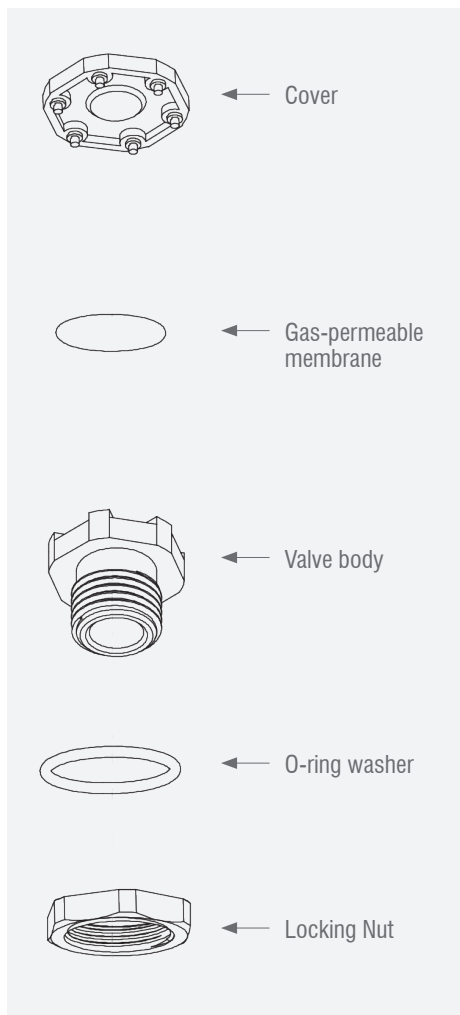

Dimensions (mm)

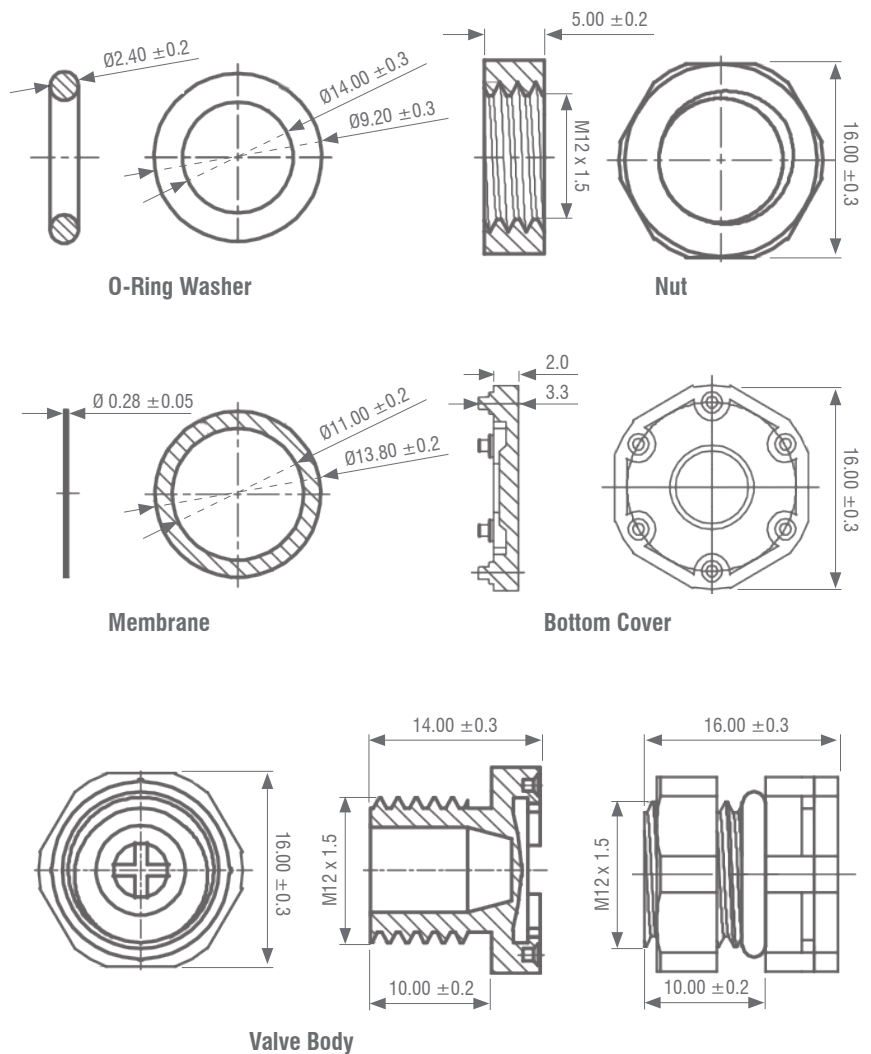

NOTE: Spanner size for Body, Bottom Cover and Lock Nut: 16mm