



QUICK START/INSTALL MANUAL

RECLAIM ENERGY C02 HEAT PUMP HOT WATER SYSTEM

INSTALLATION
OPERATION
MAINTENANCE

Panasonic



RECLAIM
ENERGY

COVERING MODEL NUMBERS (FOR STC CLAIMS):

REHP-KY-CO2-160GL
REHP-KY-CO2-250GL
REHP-KY-CO2-315GL
REHP-KY-CO2-400GL
REHP-KY-CO2-250SSEW
REHP-KY-CO2-315SSEW

DIGITAL COPY OF OUR MANUALS?

For a full set of PDF manuals and brochures, visit:
reclaimenergy.com.au/downloads OR
simply scan the QR Code below:

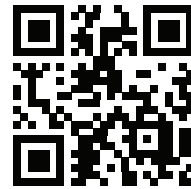

IMPORTANT

This appliance is not intended for use by persons (including children) with reduced physical, or mental capabilities, or lack of experience and knowledge, unless they have been given supervision or instruction concerning use of the appliance by a person responsible for their safety. Children should be supervised to ensure that they do not play with the appliance.

WARNING

FOR CONTINUED SAFETY OF THIS APPLIANCE IT MUST BE INSTALLED, OPERATED AND MAINTAINED IN ACCORDANCE WITH THE MANUFACTURER'S INSTRUCTIONS.

This appliance may deliver water at a high temperature. Refer to the Plumbing Code of Australia (PCA), local requirements and installation instructions to determine if additional delivery temperature control is required.

Issue 5 | December 2024

SECTION	PAGE
First Time Commissioning Procedure	4
Critical Notes	7
1 System Description	8
2 Installation Details	9
2 Before you Begin Installation	23
2 Installing the Controller	24
2 Checklist	27
3 Operation & Maintenance	28
4 Warning & Caution	34

FIRST TIME COMMISSIONING PROCEDURE

THIS IS IMPORTANT WORK FOR THE HEAT PUMP SYSTEM TO OPERATE CORRECTLY AND SAFELY. MAKE SURE TO FOLLOW THEM.

Prior to commissioning the system, all plumbing and wiring must be completed in accordance with the plumbing and wiring diagrams given in this manual.

Step 1 Plumbing completed.

Step 2 Wiring completed.

Step 3 Tank filled up with water and system is purged by PTRV and taps.

Step 4 Heat pump is purged from the bleed valves on the side of heat pump.

Step 5 Controller is plugged in and is programmed with preferred option.

Step 6 Heat pump is plugged in.

Step 7 15-30 MINUTES post commissioning, the hot water at outlet of heat pump must have reached over 60°C before the installer leaves the site. This can be done by pressing and hold of SW4 button on the PCB display of heat pump parameters 10 and 11 will show the inlet and outlet temperature of heat pump, respectively.

HEAT PUMP:

Make sure the installer completes and considers the following without fail.

- Check for water leakages
- Purge the air in the heat pump unit
- Clean the strainer
- Check circuit breaker is fully operational
- Check for water condensation
- A licensed installer should check the POST INSTALLATION INSPECTION CHECKLIST – Per Section 2.

1 Fill up the tank and check for water leakages

Operate and observe the following steps:

- 1 Open the water shut off valve **(a)**
- 2 Ensure you have filled the tank and fully purged all the air by opening a tap **(b)**, the hot water tap inside the house. Ensure you then turn the tap off.
- 3 Operate the lever of the pressure relief valve of the tank (PTRV) **(c)** to open it. Continue until water comes out of the pressure relief valve and close the lever of the pressure relief valve **(c)**.
- 4 Check that there are no water leakages from all the pipes. Check the pipe's insulation before fixing any leaks.

2 Purge the air of the heat pump unit

Makes sure the following steps are completed. If this is not done correctly, it may cause the heat pump unit to malfunction.

1 Open the 3 DRAIN TAPs

- Check if the water comes out vigorously. (Let it run with a continuous flow for more than a minute).
- Do not remove the drain plugs. (For risk of losing them)

2 Close the 3 DRAIN TAPs.

- To remove the cover, follow the figures in "Wiring". [Refer to section 2.3.5]

Make sure to purge the air since air tends to remain and cause malfunction especially when the heat pump unit pipes are long and there is a height difference.

3 Check the circuit breakers (RCD's) operation

4 Check for water condensation and noise.

- 1 Make sure there are no abnormal sounds or vibrations when the heat pump unit operates. (Refer to section 3.1)
- 2 Check that condensation water generated on the heat exchanger (Aluminum fin) of the heat pump unit's back surface is properly drained.
 - Check by pouring in approximately 300 ml of water from the back surface to the inside of the unit.



CONTROLLER:

1. Check the controller is connected to the power point and has power.
2. Connect the RJ 45 cable and initiate the purge cycle. The controller communication cable is connected to the heat pump. V1.1 controller: (RJ 45 terminal block.)
3. Select from the 6 operational mode options. After setting up the option, please go back to the main menu and press "temp" button. The current tank option and active option will be shown within seconds.

Heat Pump Unit

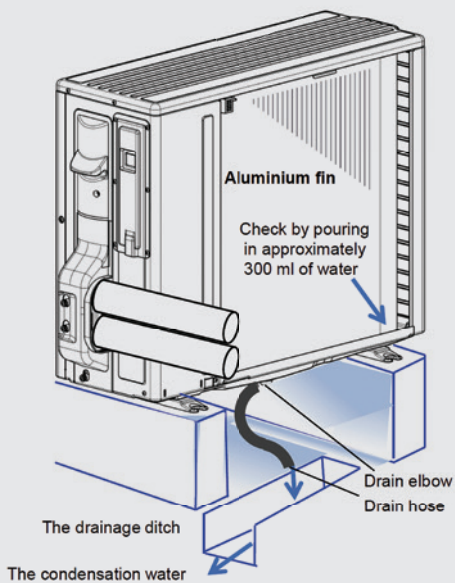
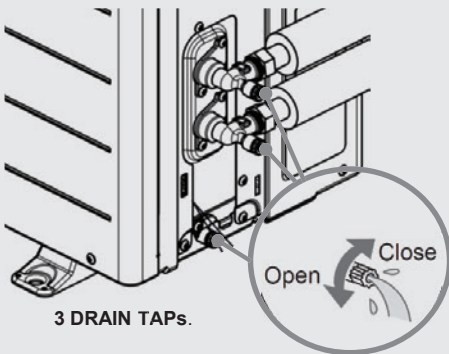

CRITICAL NOTES

NOTE 1

Remember to drain and purge the heat pump on commissioning (otherwise system might fail)
 – Refer to “Drain Plug” diagram shown below.
 Also, remember to drain from the hot water taps inside the house.

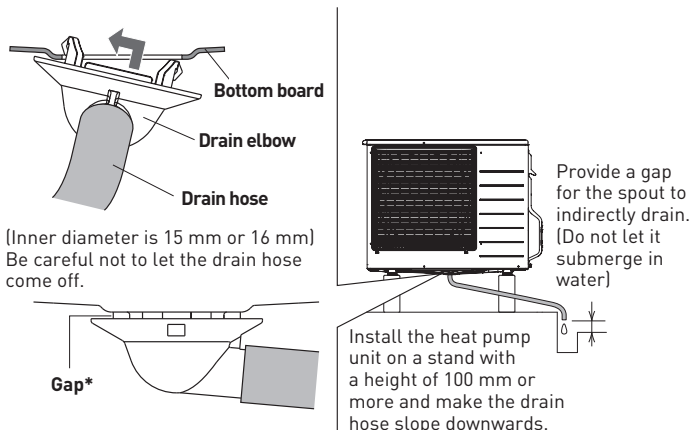

NOTE 2

We recommend a small amount of heat transfer paste be applied to the sensor probe and cable gland to increase the heat transfer between the probe and internal tank area.



We recommend a small amount of heat transfer paste be applied to the sensor probe and cable gland to increase the heat transfer between the probe and internal tank area.

NOTE 3

Maximum horizontal distance is 10m and vertical distance is 3m between heat pump and tank (max of 5 bends)

NOTE 4

Bottom tank sensor MUST be connected as part of the installation process.

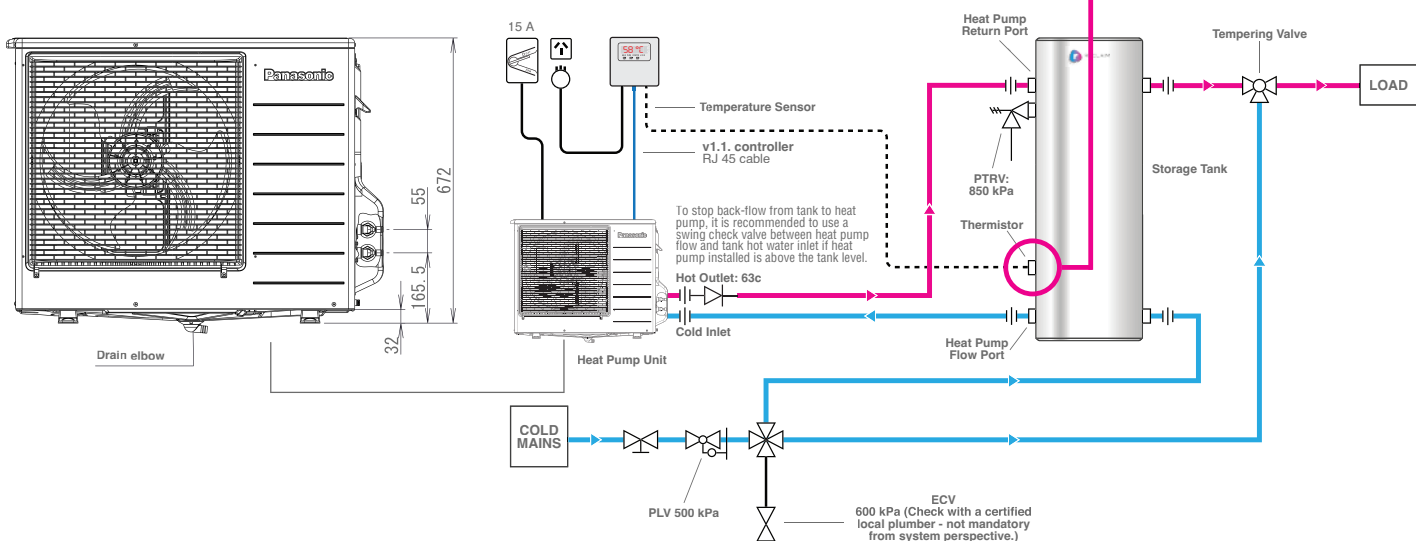

SPECIFICATIONS

- Product number:** HE-UM60AR
- External form:** The dimensions are as the following. Exterior colour : IVORY WHITE
- Included items:** Drain Elbow
- Water port connection:** (Inlet pipe, Outlet pipe) G1/2
- Fixing part:** Φ 13 mm hole [2 places], U-groove 13 mm width [2 places]

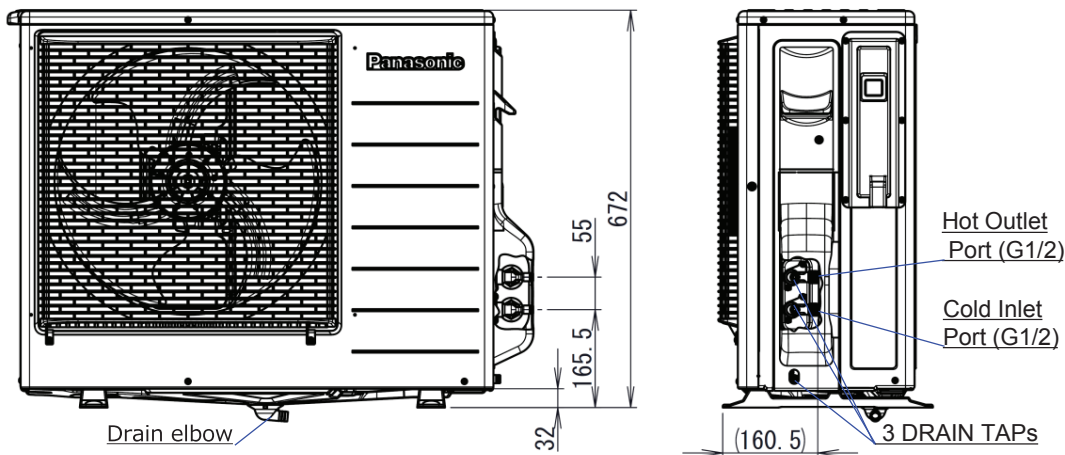
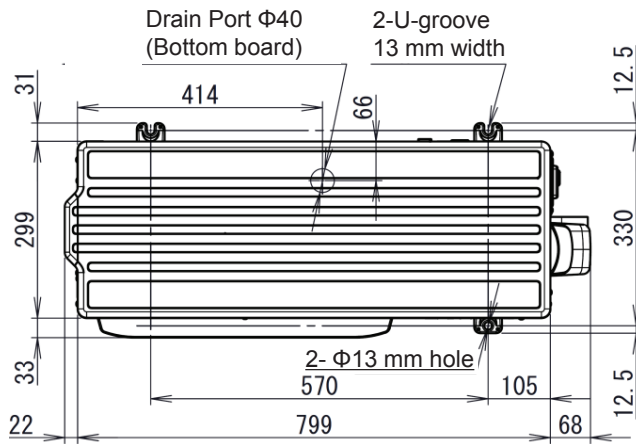

- Applicable installation atmosphere temperature: Maximum 43°C, Minimum -10°C
- Applicable water temperature: Maximum 59°C, Minimum 0°C (Liquid water)
- Applicable water pressure for the water side: Maximum 850 kPa, Minimum 200 kPa
- Applicable Voltage: AC 230-240 V (1Ph 50 Hz)
- Maximum electric current: 10 A .
- Power Supply Terminal Block: L, N, \oplus
- Supply Cable: 3 Code cable

NOTE

Please note that warranty will be voided if the system is installed without a Reclaim Energy Tank or Reclaim Energy Controller. The system will also be ineligible for any Rebates.

SYSTEM DESCRIPTION

The following system description section provides a brief overview of the Reclaim CO2 Heat Pump components and functionality.

1.1 MAIN COMPONENTS

The system components of the air sourced heat pump that customers will receive include the following:

Heat Pump Unit, Storage Tank with PTRV, Controller, Heat Pump mounting legs.

1.2 SYSTEM OPERATION

The CO2 heat pump unit receives cold water from the bottom of the tank. Using heat from the ambient air the heat pump heats the CO2 refrigerant to generate hot water. The hot water returning from the heat pump unit (fixed at 63°C) is injected into the top of the tank to provide fast hot water recovery and excellent hot water stratification. As this system delivers hot water exceeding 50°C, a tempering valve must be installed for delivery of hot water to bathrooms. Un-tempered water may be delivered to the kitchen and laundry according to AU/NZS AS 3500 plumbing code.

The heat pump operation is controlled by an external controller. The controller operates based on a sensor connected to the tank at 55% – 69% level depending on the tank model ID. The heat pump will be turned on if the temperature at the sensor level on the tank drops below 59°C for the first cycle, or 37°C for the second cycle in a day, and it will run until the tank temperature at sensor level reaches 59°C. The system controls are designed to ensure that it meets the legionella requirements, as specified in the Australian standards. In the subsequent heating cycles of every 24-hour period, the heat pump “turn off” logic is adjustable by built-in timer settings.

The default timer setting is programmed to run on continuous operation, this can be adjusted by the installer based on the homeowners’ requirements to suit their needs. More details regarding the controller operation and settings are outlined in Section 2.

At ambient temperatures below 5°C, frost may occur, if this happens the heat pump will go into defrost mode in order to protect the unit (i.e. the defrost functionality will turn the heat pump on and will normally run for no more

than 15 minutes in duration). When the unit is in the defrost function mode, the pump and fan will stop, and the refrigerant heat will defrost the evaporator. As defrost advances, the evaporator temperature will increase.

When a set temperature (pre-programmed) is achieved, the defrost operation stops and the heat pump will operate in line with its normal settings. More details regarding the controller operation and settings are outlined in Section 6.

The “operational window” refers to heat pump “hot water production” mode which can be set by using one of the options on the controller. From time to time, especially during the winter and in very cold climates, the heat pump operation may be disrupted or extended by a built-in anti-freeze or defrost operational mode. The defrost cycle can occur ONLY during the operational window to defrost the ice build-up on the evaporator at the back of the unit which is an air-CO2 heat exchanger. The defrost cycle occurs when the ambient temperature is less than about 5°C. During the defrost operation, the fan and pump stop, and the high- temperature refrigerant which is originally used for hot water production is supplied to the evaporator (=air-CO2 heat exchanger).

The frost cycle can take about 5 minutes, and this can happen multiple times depending on the ambient temperature, so in total, up to 20 minutes can be expected for the entire defrost cycle. The heat pump also comes with a built-in freeze protection cycle. Anti-freeze operation can ONLY occur outside the operational window of the heat pump and the purpose of the cycle is to protect the water circuit (i.e. piping between tank and heat pump) from freezing. If the ambient and water pipe temperatures drop below 3°C, the heat pump will activate the anti-freeze operation. During the anti-freeze operation, the heat pump works as a normal heating cycle so the fan and pump should be running. The anti-freeze operation stops when the water inlet temperature reaches 53°C or ambient temperature reaches 6°C.

INSTALLATION DETAILS

This section relates to the preparation and the installation process for the Reclaim CO2 Heat Pump Hot Water System.

The installation of a Reclaim CO2 Heat Pump can only be completed by a licensed plumber or electrician in accordance with the local standards and regulations please see:

- AS/NZS 3000 – Electrical installations rules: Electrical requirements of the system are 240v, 50 Hz, single phase, with 15 Amp circuit breaker. This appliance is to be wired with a disconnection device, as per AS/NZS 3000 wiring rules.
- AS/NZS 3500 – National plumbing and Drainage Code: The Heat Pump component of the system is to be fitted outside.
- AS/NZS 2712.2007 – Solar and Heat Pump Water Heaters: Design and Construction
- AS/NZS AS 3498—2009 – Water heaters and hot-water storage tanks.

A licensed installer must adhere to occupational health and safety guidelines and other relevant industry associations. Under no circumstances should any installer attempt to install a Reclaim CO2 Heat Pump without reading and understanding this installation manual. For any queries Reclaim Energy staff may be contacted on 1300 38 38 15.

Note: The Reclaim CO2 Heat Pump has been designed to provide hot water for domestic applications only, other applications such as space heating are not supported by this product. Installing the heat pump unit for any other application other than for domestic hot water application, will void the warranty. The installation guide for each major component of the system as well as the whole system is covered in this section.

The following sequence is recommended for installation:

1. Conduct site inspection.
2. Identify heat pump and tank installation location.
3. Plan system integration: Piping and fittings.
4. Testing and commissioning

2.1 SITE INSPECTION AND INSTALLATION PREPARATION

The very first step of installation is to find an appropriate location for the installation of the heat pump unit that includes: heat pump, tank and controller.

It is recommended that:

- To reduce the heat loss from piping, the whole system should be installed as close as possible to the main hot water points in the house (kitchen and/or bathrooms).
- The maximum distance between controller/timer, tank, and heat pump should not exceed 10m.
- It is recommended that the heat pump is installed on a concrete slab next to the tank.
- The heat pump unit **MUST** be installed outdoors; the tank can be installed indoors.
- The back of the heat pump unit draws in ambient air therefore it **MUST NOT** be covered. To have sufficient air circulation behind the heat pump, the minimum free space should be 100mm.
- The system requires one 15 Amp designated circuit for the Heat Pump and a separate GPO power outlet for the controller.
- The mounting surface of the tank and heat pump **MUST** be horizontal.
- To ascertain the clearance for the front and back of the unit – please refer to Figure 2.
- The tank **MUST** be installed on a concrete slab on the ground.
- Water supply quality must be in line with the specifications of the heat pump unit and the storage tank being installed.

INSTALLATION DETAILS CONT.

Water quality is an important aspect that can influence the systems operation and functionality. For the system to be warranted the water used in the system must meet the requirements outlined in Table 1 below.

Total Dissolved Solids	< 600 mg/L or ppm
Total Hardness (CaCO₃)	< 200 mg/L or ppm
Electrical Conductivity	850 µS/cm
Chloride	< 200 mg/L or ppm
pH Level	Min 6.5 to Max. 8.5
Magnesium	< 10 mg/L or ppm
Sodium	< 150 mg/L or ppm
Iron	< 1mg/L or ppm
Alkalinity (as CaCO₃)	< 200 mg/L or ppm
Dissolved (free) CO₂	< 25 mg/L or ppm

Table 1: Water Quality Threshold Values.

If you have doubts regarding water quality, please contact your local water authority or have a water test completed. In areas of poor water quality all major components will have a reduced life due to the hardness of the water. In areas with "hard water" (>200 mg/L or ppm), a water softening device must be installed to ensure the long-term efficient operation of the system is met.

NOTE

The Reclaim Energy glass-lined tank has a sacrificial anode to protect the vessel from corrosion. An anode inspection must be completed initially after five (5) years and then every three (3) years, thereafter.

2.1.1 COMPONENT INSPECTION

Prior to installation, please check that the following components have been provided. Any concerns must be brought to the attention of Reclaim Energy immediately.

- Heat pump unit
- Tank + PTRV
- Controller module
- Heat pump mounting frames (checked with a reseller)

NOTE

All other components required for the installation not listed here should be provided by the installer.

2.1.2 COMPONENT TRANSPORTATION

- When transporting boxes, note the orientation of "THIS WAY UP" arrows.
- Ensure all boxes are strapped and secured to prevent any movement during transit.
- All tanks must be transported upright. Stacking is not recommended for any components.
- Products should always be handled with care. Damage incurred during transportation is not covered under product warranty.

2.1.3 UNPACKING OF THE COMPONENTS

- When unpacking, take care to ensure that the components are not damaged during the process.
- Avoid using sharp blades or knives as this can scratch or damage the surfaces of the products.

2.2 HOT WATER STORAGE TANK

2.2.1 INSTALLATION LOCATION

- The storage tank must be installed at ground or floor level and must stand vertically upright, as per the manufacturers guidelines.
- Tanks must be secured on a concrete or plastic mounting slab as shown in Figure 1 below.
- The storage tank should be located as close as possible to the most frequent hot water draw off points in the building, such as the bathroom or kitchen. If the storage tank is located a long way from hot water draw points, a hot water circulation loop on a timer should be considered to reduce the time-lag for water to reach the tap. Please note, this is not supplied by Reclaim Energy, the installing plumber can provide advice and consider installing a ring main system for hot water circulation.
- The tank should not obstruct any windows, doors or exits. Clearances must be provided to make servicing and maintenance convenient without the need for a ladder or scaffolding.
- For servicing, the PTRV must be easily accessible.
- The tank should be positioned to allow room for anode removal.
- The storage tank must be installed with a safety tray, if stored indoors. The installation of the storage tank and safety tray must comply with AS/NZS 3500.4 and all local codes and regulatory authority requirements, with regards to its construction, installation and draining. Tanks installed outside must be installed on a suitable concrete slab.
- The tank label must be clearly visible.

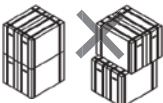

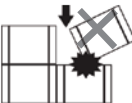



Figure 1: Concrete or heavy duty plastic slabs to be placed under the storage tank and/or heat pump.

2.3 HEAT PUMP

Before plumbing and/or wiring of the heat pump unit and integration with the rest of the system, the following sequential steps must be conducted.

WHEN TRANSPORTING THE HEAT PUMP UNIT, MAKE SURE TO NOTE THE FOLLOWING ITEMS.

- The unit is heavy, so it is recommended that two people are used to move it into position. 
- Stack the top and bottom surface in the same direction on loading platforms or in warehouses. Do not stack in parallel crosses. 
- Do not step on the units top surface. 
- Make sure and be careful so that objects do not fall or collide with the unit. 
- Do not press the side surfaces with your knee. Do not apply excessive force. 

NOTE

Please note that malfunctions and accidents caused by mounting or transporting will not be covered under warranty.

2.3.1 INSTALLATION LOCATION AND SPACING

- Install the heat pump unit horizontally on a flat surface.
- Install the heat pump unit in accordance with the spacing provided in Figure 2.

Ventilation is required for the front, back, left and the right sides of the unit. Please ensure there are no obstructions within 100 mm of the unit.

When there is no obstacle on the air outlet side [unit: mm].

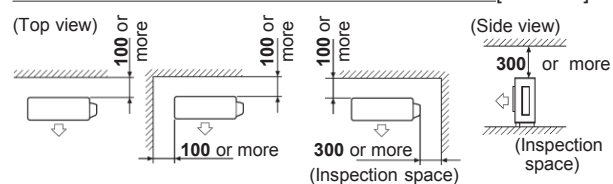

When there are obstacles on the air outlet side [unit: mm].

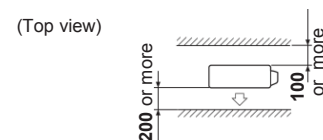
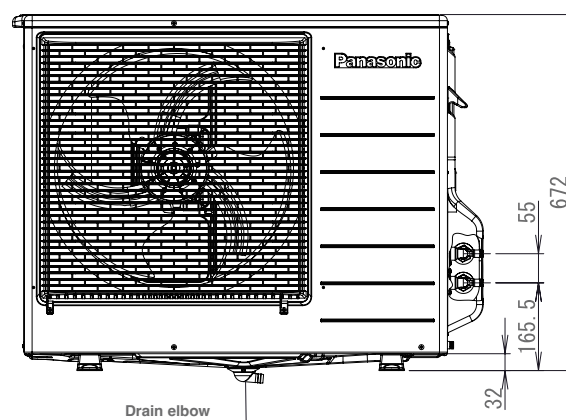

Figure 2: Required space for installation of heat pump.



IMPORTANT

THE FOLLOWING INSTRUCTIONS ARE REQUIRED TO BE MET TO INSTALL THE HEAT PUMP UNIT.

For coastal areas, install in the following places. (Otherwise, it may cause a malfunction)

- Places where sea water and/or sea breeze do not directly impact the heat pump offering protection.
- Places with good drainage.
- Places where salt etc built up on the main body of the heat pump hot water system can be thoroughly washed away by rainwater.

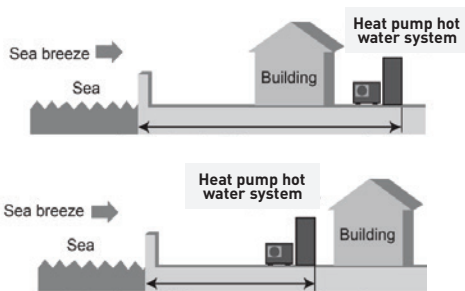

Install the heat pump unit in a place that fulfils the following conditions with the customer's consent.

- Avoid installing the unit in the following places.
- Places where the lowest temperature becomes lower than -10°C .
- Places that are near fire or flammable items.
- Special places such as hot spring areas.
- Install in a place where no problem will arise if the water flows out and where water proofing and draining can be done.

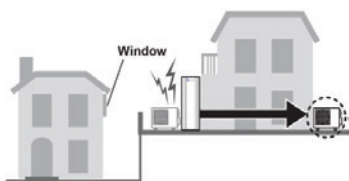

- Lead the discharged drain water to the drain.
- Install in a place where you can ensure space of the surrounding for loading and unloading, pipe work, maintenance inspection, and performance maintenance.

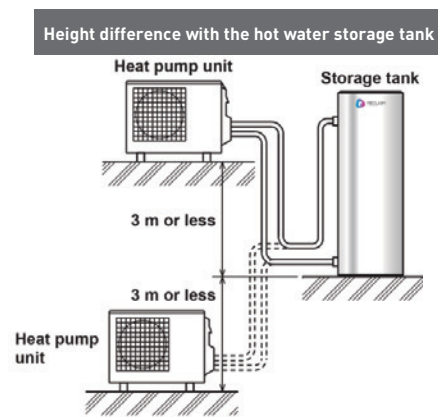

Installation place of the heat pump unit

- Make sure the installer considers the following related to noise of the heat pump.
- Avoid installing the heat pump in the following locations.
- Near bedrooms or windows.
- If vibration during operation disturbs you, take an appropriate measure to reduce it, such as installing an anti-vibration rubber on the stand of the heat pump unit.
- Make sure to fulfil the environmental standards related to noise for the Australian and New Zealand standards

INSTALLATION DETAILS CONT.

- Cold air will blow from the air outlet during operation, avoid installing in locations where the surroundings may be impacted.
- Install the heat pump unit outdoors in a well-ventilated area where accumulated snow etc. will not be a hindrance.
- Keep the unit at least 3 m away from TV antennas or wireless devices, and 2 m away from associated main body and cables.
- Do not install in areas with high levels of sulphide gas components and/or locations that have a lot of oil such as machine oil etc.

[Avoid installing in locations where strong wind blows continuously. The fan rotates on high speed.]

- Do not install the heat pump unit near the supply/exhaust pipe of a combustion device.

Height difference with the hot water storage tank

- Confirm the piping conditions for when there is a height difference then decide on the installation location.

Installation space required for the heat pump unit

- Ensure to open at least 3 directions out of the front, back, left, and right for the air outlet side to secure a ventilation path.
- If only 2 directions can be kept open, the boiling capacity may decrease.
- If the installation space is small, frost or condensation water forms on the entire surface of the heat pump unit, which causes it to get wet.
- If there are any obstacles such as walls in the surroundings, follow the instructions on the figure 2.

2.3.2 MOUNTING

Note: Reclaim Energy ASHP **MUST** be installed on the ground with mounting frames that is a default supplied component **OR** on the wall with brackets. Note: A plumber needs to have access to the underneath and to the side of the unit for maintenance.

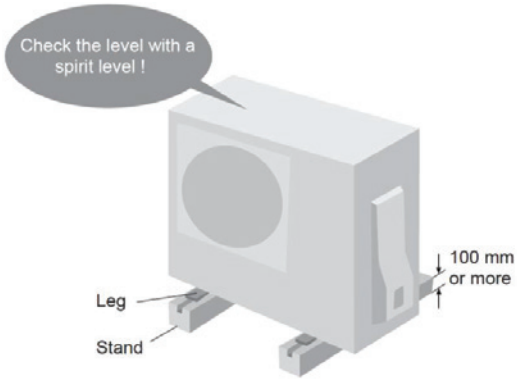

Figure 4: Ground mounting frames.



Figure 5: Wall mounting brackets

THE FOLLOWING INSTRUCTIONS ARE REQUIRED TO BE MET TO INSTALL THE HEAT PUMP UNIT.



1 Install the stand (Resin stand)

- Install a stand with a height of 100 mm or more on a horizontal surface outdoors. Do not place the heat pump unit directly on the ground.
(Failure to do so may result in poor drainage of drain water, resulting in equipment damage)
- Use a stand that has an allowable loading mass of 50 kg (allowable load of 490 N or more) or more.

2 Fix the stand's legs with bolts (4 places)

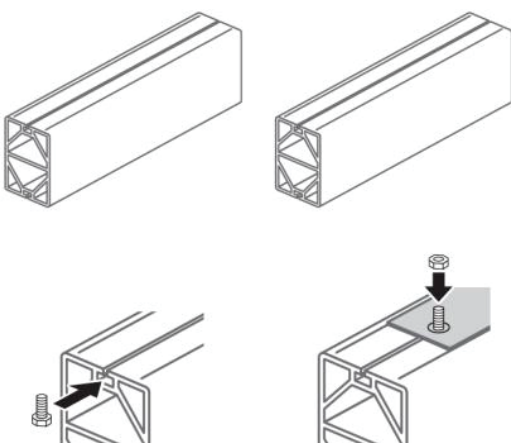

3 Check the level with a spirit level

- Avoid installing in places where water accumulates when it rains or snows, places where snow drifts or falls, and/or where sewage gas flows backwards.

WHEN HIGH STANDS ARE NECESSARY

For snowy areas, use a high stand to keep the unit from getting buried in the accumulated snow.

If water cannot be drained due to freezing, DO NOT USE A DRAIN ELBOW.

When using a high stand, select a stand that can withstand the mass of the heat pump unit, and take appropriate measures to secure and prevent the unit from falling, such as fixing it using anchor bolts.

- Since drain water flows directly from the drain port, water may flow around the installed stand and freeze. When installing on the foundation of a house such as beams etc., lead the drain water to the drain using a suitable method so that it does not freeze.

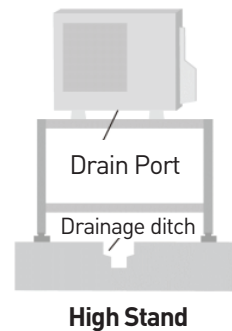

INSTALLATION DETAILS CONT.

2.3.3 ATTACHING THE DRAIN ELBOW PLUG

A drain plug is supplied in the bottom side of the heat pump unit box packaging as shown in Figure 7. Per schematic shown, safely connect the drain elbow and guide the drain hose to the ditch if required.

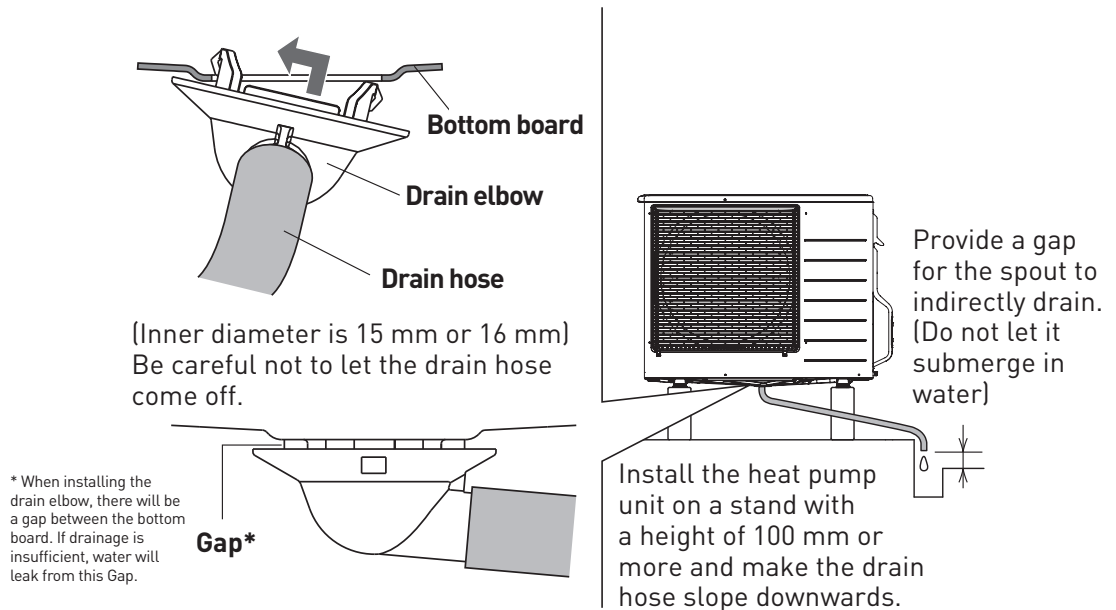
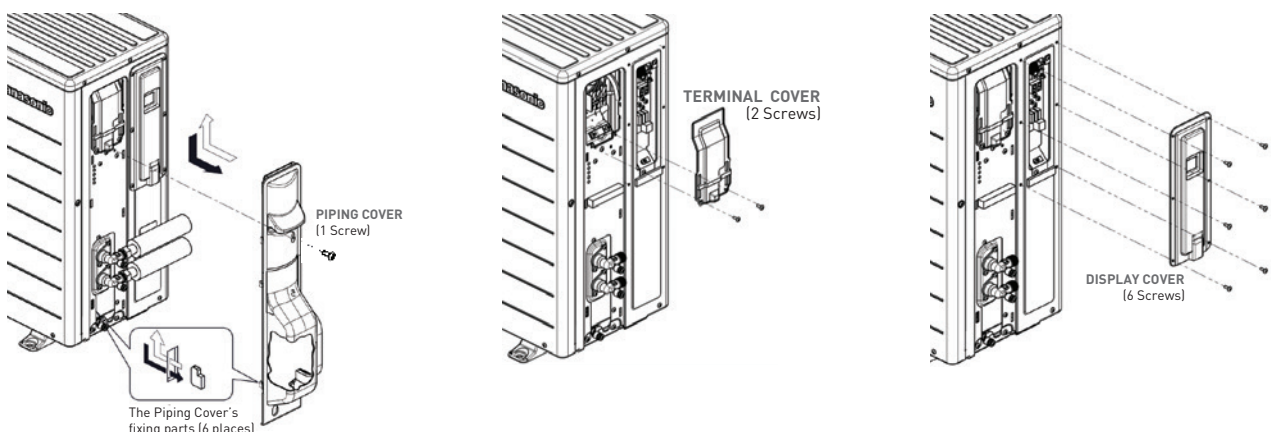

Figure 7: How to attach drain elbow.

2.3.4 REMOVING/ATTACHING THE PIPING COVER

For the piping cover, terminal cover, and display cover, follow the steps below to correctly detach and fix them. (Otherwise, it may cause the connecting wire to break or cause smoke and fire due to water entering)



1 How to remove and reattach the **Piping Cover** for piping and wiring. (1 Screw)

- All the Piping Cover's attachment parts (6 places) should be attached correctly.

2 How to remove and reattach the **Terminal Cover** for wiring. (2 Screws)

3 How to remove and reattach the **Display Cover** for wiring. (6 Screws)

2.3.5 HEAT PUMP WATER PIPING INSTALLATION

After removing the right-side piping cover of heat pump unit, the heat pump cold (inlet) and hot (outlet) pipes (connection ports) will be accessible as shown in Figure 9.

The hot water outlet from the heat pump should be plumbed up to the top port on the tank (i.e., marked heat pump return on the tank). The cold-water inlet to the heat pump should be drawn from the bottom of the tank port (i.e., marked heat pump flow). It is recommended you minimise this, as much as possible.

There should be no valves, such as non-return valves or strainers, installed between heat pump and tank plumbing. The piping should have no restrictions. All hot pipes including the PTRV must be fully insulated.

For domestic installations, the recommended pipe is copper, with the following dimensions. 1/2" / 12.7mm. PEX piping systems not to be used.

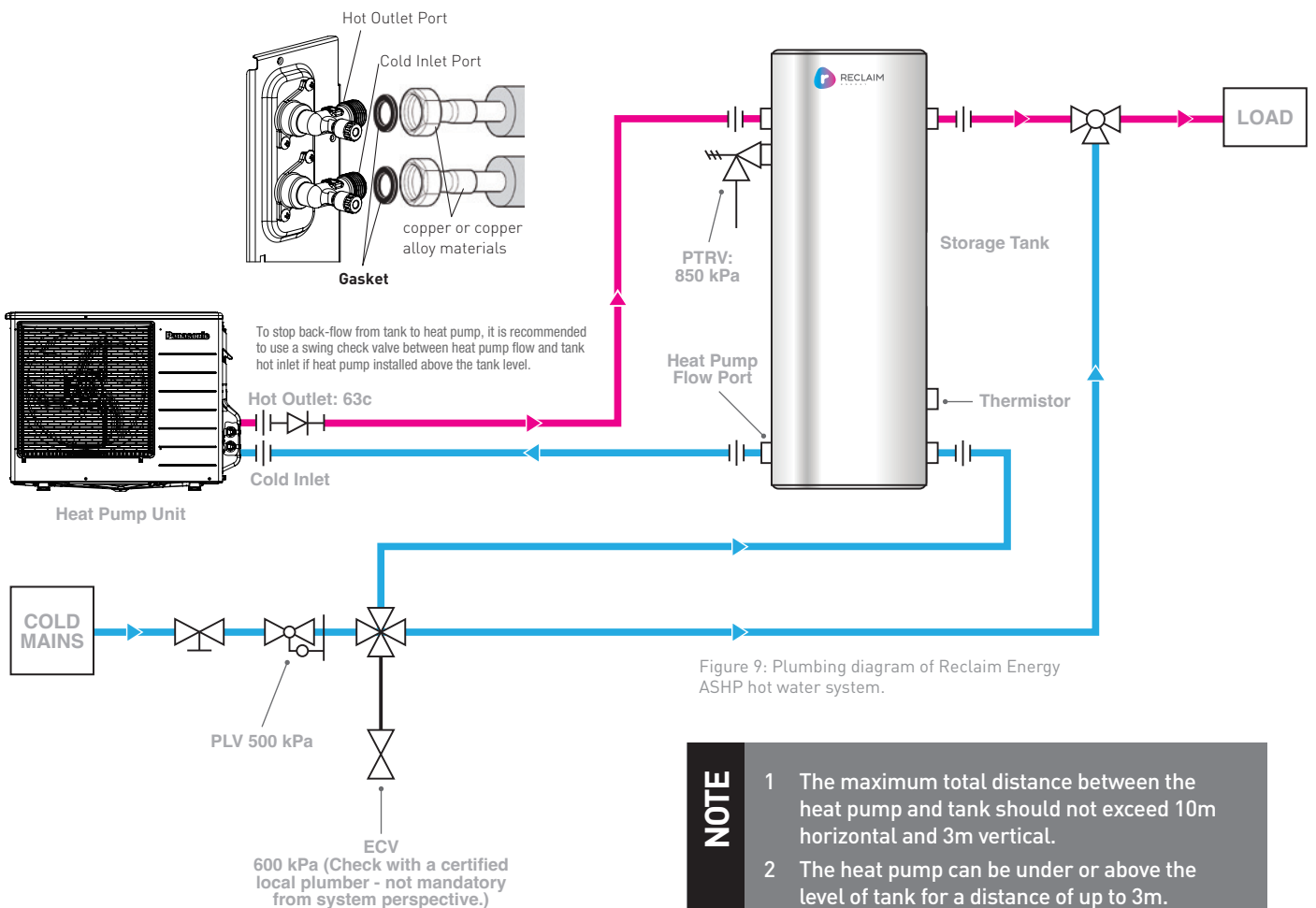

Figure 9: Plumbing diagram of Reclaim Energy ASHP hot water system.

IMPORTANT

Do not supply power to the controller or heat pump unit before conducting the full air purge process as per commissioning stages, completing the wiring of heat pump power supply, and wiring of the controller.

- NOTE**
- 1 The maximum total distance between the heat pump and tank should not exceed 10m horizontal and 3m vertical.
 - 2 The heat pump can be under or above the level of tank for a distance of up to 3m.
 - 3 The maximum number of bends allowed is 5.
 - 4 Do not put any restrictive valves such as check valves or strainers in the heat pump flow/return lines. This will void warranty and affect the unit's performance.
 - 5 A 15 A isolator switch is recommended to isolate the heat pump unit.
 - 6 Sensors should be entirely pushed into the tank and securely tighten the gland.

INSTALLATION DETAILS CONT.

THE FOLLOWING INSTRUCTIONS ARE REQUIRED TO BE MET TO INSTALL THE HEAT PUMP PIPING & DRAINING.

- The system should be directly connected to the water supply and should be carried out by a certified plumbing contractor using the specified piping materials and in accordance with Australian and New Zealand standards.
- Make sure to use water that meets the water quality standards for drinking water stipulated by water supply laws.
- Do not use well water. Additionally, avoid using the heat pump unit with water containing a lot of salt, lime, or other impurities and in areas with acidic water, even if it complies with the national water quality standards. CaCO₃ will form scaling within the heat pump unit's heat exchanger, and water will not be able to boil in a short time.
- Do not connect to a solar hot water system. The high temperature water may cause a malfunction of the heat pump unit.
- Do not bury the heat pump unit piping. (Otherwise, it may cause the boiling temperature to be lower)
- Do not connect a non-return valve or a valve with a check valve for the heat pump unit piping. (Otherwise, it may cause a malfunction of the heat pump unit)
- Make sure to install a shut off valve on the water supply side, water distribution piping, water distribution valve that leads to a drainage point, in accordance with the laws and regulations. It is needed for draining water when not in use for a long period of time, and for cleaning the inside of the tank. Locally prepare other pipes and piping materials.
- For the heat pump unit piping, make sure to use copper or copper alloy materials that comply with the laws and regulations. Do not use pipes made from resin.
- Do not use the existing pipes if they have deteriorated.
- Cover the tips of the pipes until they are connected to prevent foreign matter from entering. (Otherwise, this may cause a malfunction)
- Confirm that foreign matter such as sand etc., is not mixed in the water supply. (Otherwise, it may cause a malfunction)
- When connecting pipes, use one gasket for each connection. Do not connect by layering two gaskets etc.

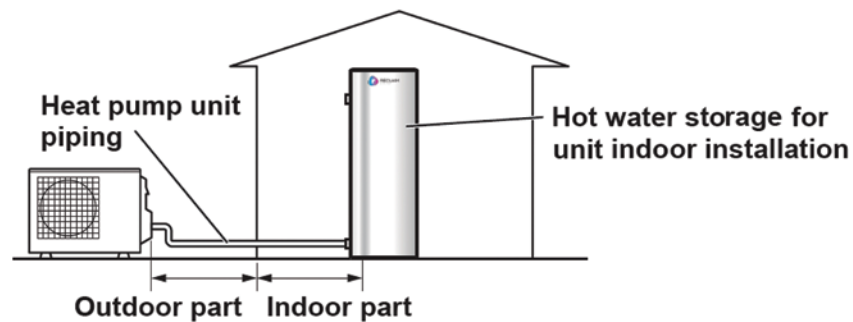

- The water supplied to the heat pump piping contains chlorine components that rise to high boiling temperatures shown below for a long period of time.

For the piping materials and connecting parts (gaskets), only use materials and parts that are guaranteed by the supply manufacturer. (Otherwise, it may cause water leakage)

Boiling temperature:

Standard 63°C. Special mode 70°C, 75°C, 80°C

MATERIALS	PIPE LENGTH	PLACES USING AN ELBOW PIPE (ONE WAY)	THICKNESS OF THE INSULATION MATERIAL
Copper Pipes: Φ12.7	Standard: 5m Maximum: up to 15m	5 places or less	15mm

DRAINAGE

When the heat pump unit is operating, a maximum of approximately 300 ml of drain water is generated per minute.

To ensure drainage, make sure to observe the following points. Otherwise, the inside of the unit may corrode and become damaged.

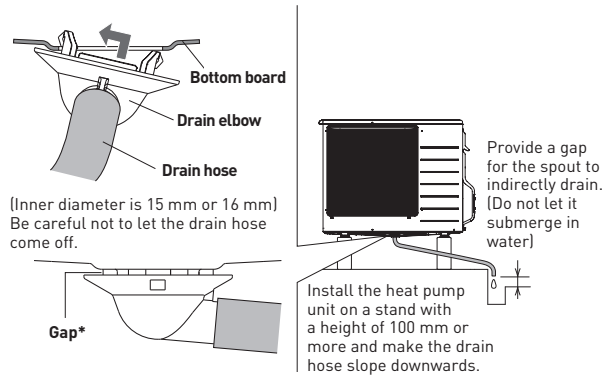

* When installing the drain elbow, there will be a gap between the bottom board. If drainage is insufficient, water will leak from this Gap.

WATERPROOF THE INSTALLATION PLACE

Perform drainage construction in accordance with the local laws and regulations so that water does not accumulate during draining.

- 1 The drain hose must be constantly sloped downwards.
 - Do not let it pass over the stand
 - Do not let it wave
- 2 Make sure an outlet gap is between the drain hose outlet and drain and indirectly drain water.
 (Do not let the drain hose tip submerge)
- 3 Do not place the tip of the drain hose or PVC pipe directly on the ground or bury it in the ground.
 - If horizontal piping cannot be avoided, use a high stand, and make the downward slope 1/50 or more with a PVC pipe that has an inner diameter of 15 mm or more.
 Take measures so that the inside of the pipe does not get clogged with foreign matter or frozen drain water.
- 4 Do not join the drain hose with other drainpipes, install it on its own. (Otherwise, it may cause backflow)

Make the stand higher if necessary so that the drain hose slopes downwards.

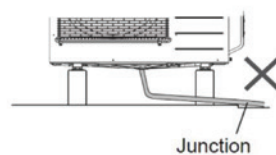
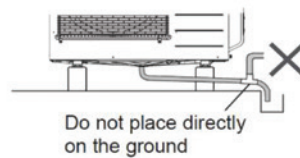
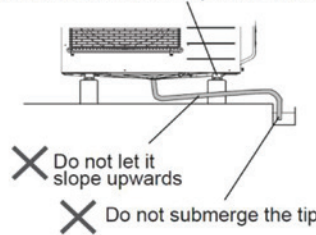

NOTE

Please note that malfunctions and accidents caused by piping or drain construction will not be covered under warranty.

THE FOLLOWING INSTRUCTIONS ARE REQUIRED TO BE MET TO AVOID PERFORMANCE FAILURE.

- Do not use anything other than the specified items such as twin tubes, and rubber hoses etc.

Use flexible stainless pipes that are 50 cm or less only when position adjustments of the connection are necessary.

(Otherwise, it may cause problems such as heat pump unit failure, increased water leakage, and foreign matter entering the tank etc.)

- Pipe according to the requirements of the piping material.
- The height difference of the inverted U-shaped piping should be up to $a+b < 3$ m with only 1 inverted U-shaped piping.
- Cover the tips of the pipes until they are connected to prevent foreign matter from entering.
- Make sure to connect the piping without mistaking the hot water side and cold-water inlet side. (Otherwise, operation will stop)
- For the heat pump unit pipes and connecting parts, use gaskets that can withstand a water quality containing high temperature chlorine.

Only use materials that the manufacturer approved as suitable.

- A 20 Nm (15 to 25 Nm) pipe fastening torque is used for the work example, but use the torque recommended by the manufacturer of the gasket you are using. (Otherwise, it may cause water leakage over time)

- Remove the piping cover. [Refer to section 2.3.4]
- Set the gasket onto the pipe.
- Hand-tighten the screw part straight until it is properly fastened.
- Lightly pull the pipe, and check that the flange tip of the pipe and the nuts are closely attached and are not wobbling. (Otherwise, it may cause damage to the screws or water leakage)
- Fasten with 20 Nm (15 to 25 Nm) using a torque wrench.
 - Make sure to use a spanner to hold it in place as you fasten with the torque wrench.
- After confirming that there are no water leaks, perform insulation.
 - Prevent heat loss and freezing by installing insulation material in a way so that the connecting parts are not exposed.
 - Use weather resistant materials for the insulation material.

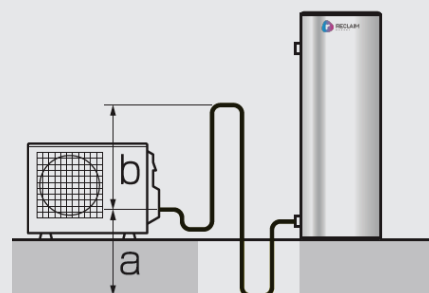

1 Piping Cover
(1 Screw)

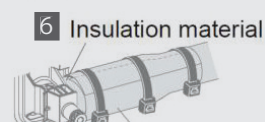
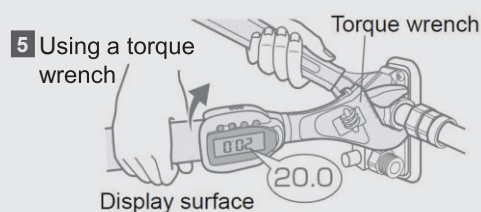
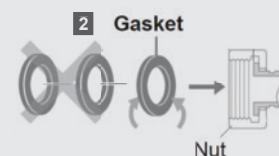
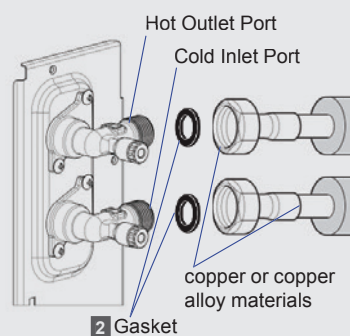
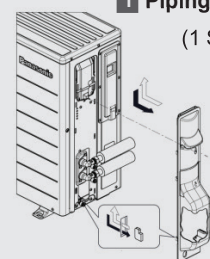

INSTALLATION DETAILS CONT.

2.3.6 SYSTEM WIRING

A licensed electrician should install the system with regards to the wiring diagram provided in Figure 10 and in accordance with local/national wiring codes. The power cord chosen must be compliant with AS/NZS 3191 and the nominal cross-sectional area should be 1.5 mm² or more.

It is notable that the heat pump must be installed on its own circuit (i.e. 15 A circuit)- AND hard wired to a 15 A ISOLATOR SWITCH. The controller has its own plug and must be connected to a separate power point. The power point supplying the controller can be fed from the heat pump circuit.

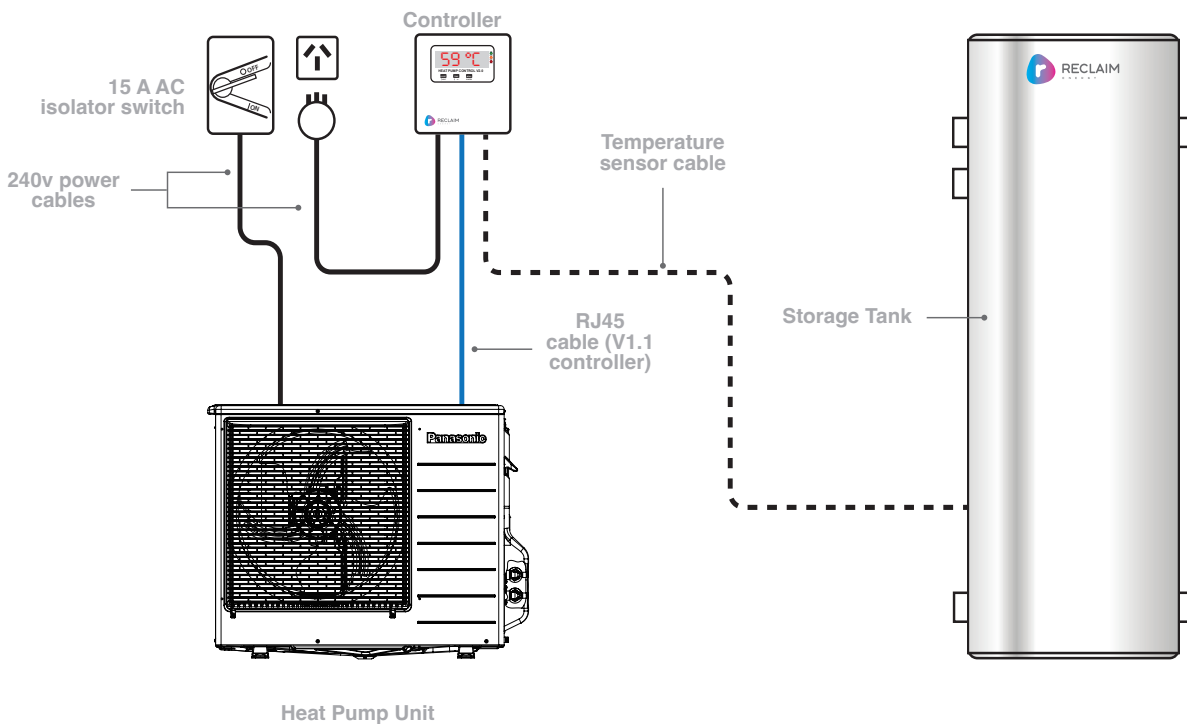

Figure 10 Wiring diagram of Reclaim Energy ASHP hot water system.

IMPORTANT

Do not supply power to the controller or heat pump unit before completing the plumbing and air purge process, as well as the wiring of the heat pump and controller.

INSTALLATION DETAILS CONT.

POWER SUPPLY TERMINAL BLOCK:

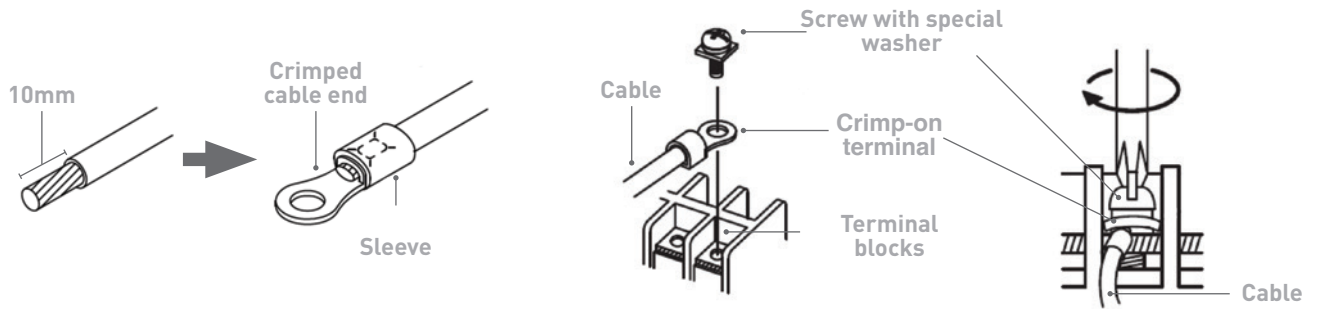
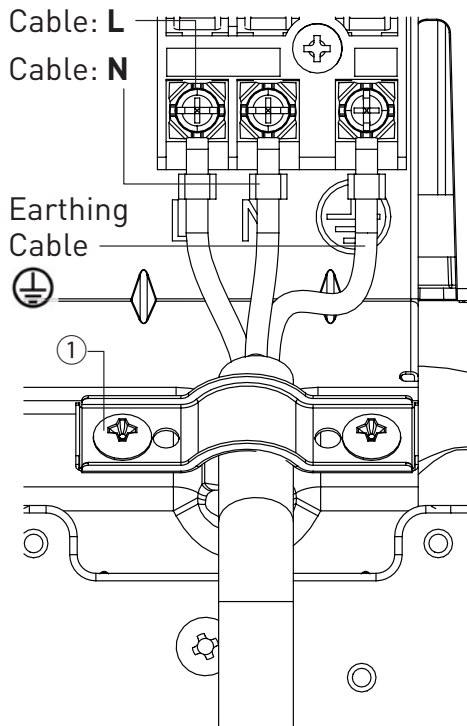

Figure 12: How to attach the power cable.

THE POWER CABLES NOMINAL CROSS-SECTIONAL AREA

More than 1.5 mm²

1.5 mm²



1. The power cable must be fixed with metal fitting using a pair of the screws.

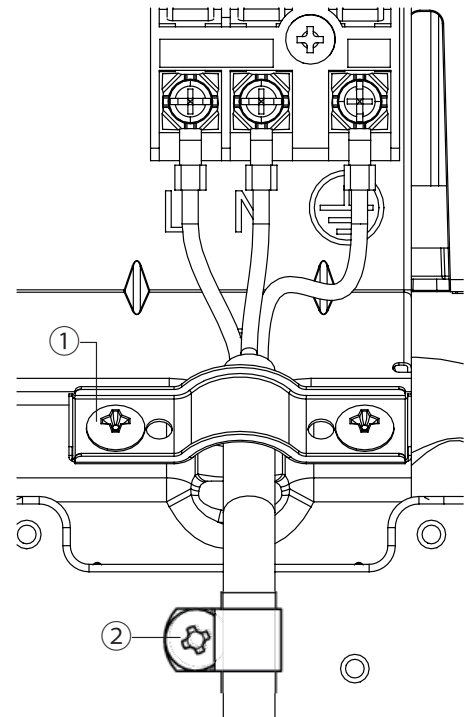

2. In this case the power cable must be fixed also with the Resin wiring clamp using a screw.

2.4 CONNECTING V1.1 CONTROLLER TO THE HEAT PUMP

BEFORE YOU BEGIN INSTALLATION

Case tools required	Philips 1 screwdriver for lid screws (if required to remove cover) Pozi 2 screwdriver for mounting screws
<p>READ THESE SAFETY PRECAUTIONS and LIMIT OF LIABILITY BEFORE YOU BEGIN</p> <p>The following pages contain instructions for qualified personnel only. They involve potentially hazardous adjustments and high voltage mains wiring information.</p>	
General Safety Precautions	All servicing is to be carried out by qualified personnel only. All aspects of the installation must comply with local electrical and plumbing regulations.
WARNING	These products are not designed for use in, and should not be used for, applications which are in conjunction with items that are critical to any person's health (e.g. life support systems). In any critical installation, independent fail-safe back-up systems must always be implemented.
Installation Precautions	<p>Make sure the controller is installed out of direct sunlight, flammable liquids or radiant heat sources. Power leads must face directly down.</p> <p>Ensure controller is in a safe environment for users to inspect display panel.</p> <p>Sensor leads should be kept 300mm (12 inches) away from mains and comms cables if run parallel to those cables.</p> <p>A readily accessible power disconnect device is required.</p>



CAUTION

Dangerous Voltages may be present. No user serviceable parts.

Protective enclosure must only be opened by qualified personnel.

Remove ALL power sources before removing protective cover. The Reclaim Controller must be installed by a qualified person.

Ensure suitable over-current protection and RCD protection for the Reclaim Controller is in place.



INSTALLING THE RECLAIM CONTROLLER

Mounting	<p>Follow these steps:</p> <ol style="list-style-type: none"> 1. Allow for the enclosure dropping 5mm (1/5 inch) from screw centres once mounted (keyhole mounting). 2. Place the printed drill guide template (that ships with the controller) against the wall, checking for level alignment. All four mounting holes should be used with at least two firmly secured into wood or masonry. 3. Mark and drill/screw as appropriate leaving the heads of the screws above the surface by approximately 3mm (1/8 inch). 4. Place the unit over the four screw heads. The unit should slide down 5mm into the 'key' slots and become secured to the wall. You might need to adjust the screw height to obtain a secure fit.
Sensor Mounting	<p>WARNING: It is CRITICAL the sensor is mounted correctly for accurate readings, safe and efficient operation of the system and durability of the sensors.</p> <p>The sensor should be fitted into a dry metal immersion 'pocket' in the hot water cylinder. Apply plenty of heat transfer compound (available from your distributor) between the sensor and the lining of the 'pocket', then seal against water ingress where the cable meets the cylinder with neutral cure silicon.</p>
Connect to Heat Pump	<p>Plug RJ45 cable into the heat pump.</p>
Connect PV Remote wires (only if applicable)	<p>A 'clean set of contacts' (passive only) is expected for this input. If not, then the controller could be damaged.</p> <p>The remote input is accessible by removing the cover. Ensure mains power is isolated during this work.</p> <p>Loosen the cable gland and thread the cable next to the sensor cable.</p> <p>Wire in as indicated on diagram on the right.</p>
Plug in the controller to the power source	<p>Before power up read all safety instructions, warnings, and liability statements.</p> <p>Controller will run through start up checks including lighting all LEDs. The first display will be the time of day the controller thinks it is. Page 7 has details on how to adjust the time.</p>

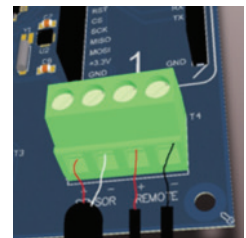

SENSOR REMOTE

RECLAIM CONTROLLER WITH THE COVER REMOVED

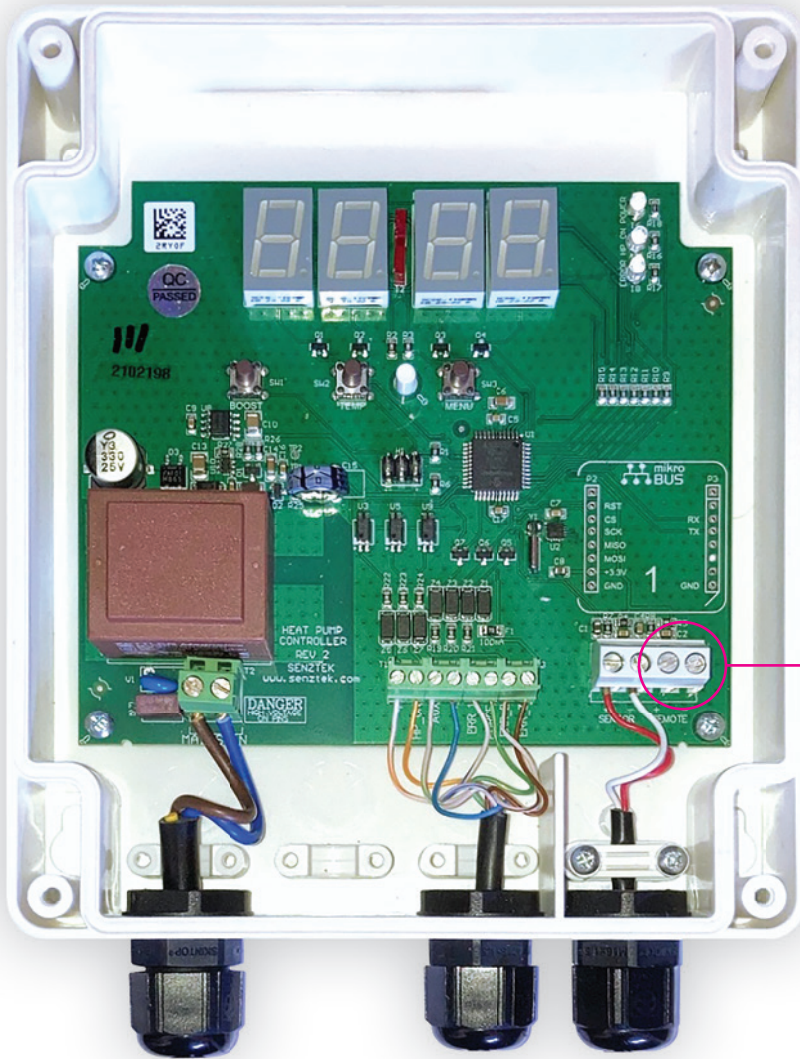

Dry contact terminals for option 6 (page 9).



CONTROLLER KEY FUNCTIONS

Regardless of the version of controller received, the installer must ensure the following:

1. The controller power cable is wired up to the power point
2. The controller communication cable is correctly wired up to the heat pump
 - a. RJ 45 cable for V1.1 controller
3. With reference to the controller manual
 - a. The time of day is correctly selected on the controller
 - b. The operational mode is set per customer requirement (i.e., default is option 1)
4. The heat pump is purged by the controller during the commissioning of the heat pump unit
 - a. Press and hold the "menu" or "OK" button on the controller to initiate the 5-minute purge cycle
5. Before installer leaves the site, he/she must ensure that the heat pump receives signal from the controller and the "heat up" process has been started (i.e., fan is spinning, and hot water outlet pipes are hot and have reached +60°C). If time of day contradicts the option settings, the system will not run as required. If the option selected is outside normal time it is recommended the heat cycle is activated using the boost function.

2.5 POST INSTALLATION INSPECTION CHECKLIST

A licensed installer should check for the following before leaving the installation site.

System check: Check all connections for leaks and that all components are installed, as per this manual.

Take photos of all system components with clear serial numbers for warranty purposes. This should include photos of the plumbing lines to and from the tank, heat pump and sensor port connection.

Note down the Tank Serial Number

Note down the Heat Pump Serial Number

Note down the Controller Serial Number

Fill out the installation record form supplied for system warranty and service issues.

Submit your Installation Record Form via Email: warranty@reclaimenergy.com.au

Complete the rebate forms for the system prior to leaving the site, this will require the installer's signature. Note these forms are not supplied with us or in this document. This is responsibility of customer or installer to have the rebate forms ready to fill out.

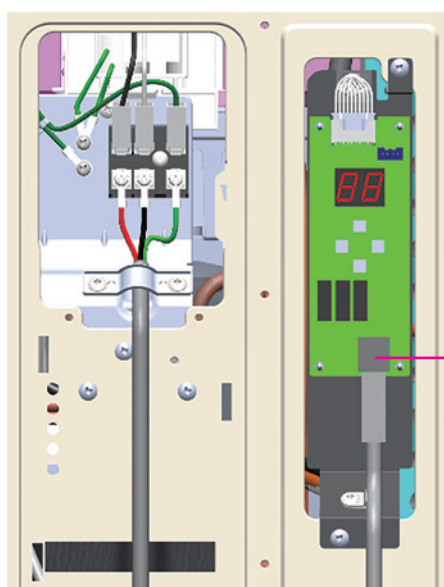

For the Remote Controller, connects to the RJ45 terminal on the PCB display

CHECKLIST

ITEM	CHECK
GENERAL	
Water supply is in accordance with water quality standard.	
There is no leakage from the pipes.	
There is no flammable hazardous materials around the unit.	
There is no damage, deformation, or contamination to any components.	
There is enough space for inspection / repair of each component?	
The floor below the tank/heat pump has been properly waterproofed and can support the component.	
Hot water is available with enough pressure at the taps inside the house.	
HEAT PUMP	
The heat pump unit has been installed properly in line with these guidelines.	
The drain plug is properly closed	
The drain of heat pump unit is in the correct position to drain.	
A two-step air purge operation has been completed successfully.	
The wiring cover on the heat pump is correctly closed.	
TANK	
The operation of PTRV is normal.	
The tank is fixed in place with anchor bolts if necessary.	
PIPING/WIRING	
The mains breaker is of the correct size and voltage Breaker can be turned off, local disconnect is in place. The movement of circuit breaker is correct.	
Power supply wiring, ground wire, and "On/Off RJ45 cables" are fixed firmly.	
Union joints are used so that the parts can be easily removed.	
The insulation work for piping has been conducted properly.	
CONTROLLER	
Check all 3 connections are correctly firm and in place: 1 – communication (RJ45 patch or Modbus) cable to heat pump unit, 2 – Sensor cable to tank, 3 – Power is connected.	
Correct time of day has been set up on the first powering.	
Controller operational mode (OPTION modes) has been set up with reference to the customer requirements.	

OPERATION AND MAINTENANCE

3.1 HEAT PUMP

3.1.1. CHECK FOR THE OPERATIONAL MODE

It is recommended that the end user check the operation of the heat pump matches with the options setting, at least once per month. If the heat pump runs outside the settings of the active option, this needs to be escalated to the local service agent and/or Reclaim Energy representative for troubleshooting. There are some possibilities for running outside of the settings of controller such as 1) tank sensor is loose and controller does not read the correct temperature of the tank 2) in winter, the system can undergo freeze or frost protection cycles which are additional cycles compared to normal settings 3) Boost function has accidentally been activated.

3.1.2. CHECK FOR AIR FLOW/ WATER BLOCKAGE

It is recommended that the drain tray of the heat pump is checked at least once a year for possible blockages. The same applies to the surrounding area of heat pump, and if plant is growing around the heat pump, that needs to be trimmed frequently to allow for the natural ventilation of the system.

3.1.3. CHECK FOR ERROR CODES

Apart from running outside the cycle of operational modes, should the heat pump or controller run into an issue, the controller or heat pump generates an error code, or simply the end user will run out of hot water. Each error code on the controller has its corresponding error code label on the heat pump PCB display. If there is an error code on the controller but PCB display does not show an error, this can imply that the communication cable is damaged or not working (i.e. possible controller fault or communication cable fault). Table below summarises the full list of error codes and possible solutions.

ERROR CODE TABLE

ERROR CODES		SUSPECTED AREA OF ISSUE		INITIAL CHECKS REQUIRED	TROUBLESHOOTING	ERROR RESET
REMOTE CONTROL	PCB					
Eg-1	H9	"Outdoor temp. sensor error"	Outdoor temp. sensor connector	Check the sensor connection is properly installed/inserted fully.	"In case of abnormal connection, reinstall correctly. In case of defect, replace with new temp sensor"	Auto
			Outdoor temp. sensor	Check the resistance value with tester.	If resistance value is abnormal, replace new temp sensor.	
			PCB(Main)	-	Replace PCB(Main)	
	HC	"Water outlet temp. sensor error"	Water outlet temp. sensor connector	Check the sensor connection is properly installed/inserted fully.	"In case of abnormal connection, reinstall correctly. In case of defect, replace with new water outlet temp sensor."	Auto
			Water outlet temp. sensor	Check the resistance value with tester.	In case the resistance value is abnormal, replace new water outlet temp sensor.	
			PCB(Main)	-	Replace PCB(Main)	
	J3	"Discharge temp. sensor error"	Discharge temp. sensor connector	Check the sensor connector connection is properly installed/inserted.	"In case of abnormal connection, reinstall correctly. In case of defect, replace new discharge temp sensor."	Auto
			Discharge temp. sensor	Check the resistance value with tester.	In case the resistance value is abnormal, replace new discharge temp sensor.	
			PCB(Main)	-	Replace PCB(Main)	
	J6	"Defrost temp. sensor error"	Defrost sensor connector	Check the sensor connector is properly installed/inserted.	"In case of abnormal connection, reinstall correctly. In case of defect, replace new defrost temp sensor."	Auto
			Defrost sensor	Check the resistance value with tester.	In case the resistance value is abnormal, replace new defrost temp sensor.	
			PCB(Main)	-	Replace PCB(Main)	
	J8	"Water inlet temp. sensor error"	Water inlet temp. sensor connector	Check the sensor is properly installed/inserted.	"In case of abnormal connection, reinstall correctly. In case of defect, replace new water inlet temp sensor."	Auto
			Water inlet temp. sensor Check	Check the resistance value with tester.	In case the resistance value is abnormal, replace new water inlet temp sensor.	
			PCB(Main)	-	Replace PCB(Main)	
Eg-2	E6	Unit rotation failure	Unit connector	Check unit connector is properly installed/inserted.	In case of abnormal connection, reinstall correctly and, reboot HPU.	Power OFF
			PCB or HP unit	-	"Replace PCB(Main) After PCB replacement, if the same malfunction still exists, replace HPU."	
	U0	Refrigerant cycle failure	Discharge temp. sensor	Check the resistance value with tester.	In case the resistance value is abnormal, replace new discharge temp sensor.	Power OFF
			Expansion valve coil	Check the coil connector is properly connected.	"In case of abnormal connection, reinstall correctly. In case of defect, replace expansion valve coil."	
			PCB (Main) or HP unit	-	"Replace PCB(Main) After replacement, still exists same malfunction, replace HPU."	

Table 11: Details of error codes on external controller and heat pump PCB display and troubleshooting process

CONTINUES ON NEXT PAGE...

ERROR CODES		SUSPECTED AREA OF ISSUE		INITIAL CHECKS REQUIRED	TROUBLESHOOTING	ERROR RESET	
REMOTE CONTROL	PCB						
Eg-3	E1	PCB circuit failure	PCB	Reset power supply.	"Replace PCB(Main) After replacement, if malfunction still exists replace HPU."	Power OFF	
	E8	Input current failure	Low power voltage		Check the power voltage.	Select a suitable power supply route or correct the source of abnormal voltage.	Power OFF
			Installation condition		"Confirm there is sufficient space surrounding the HPU as per the installation manual".	"If insufficient space surrounding HPU reinstall into a suitable space that allows for suitable air flow volume. In case of any obstruction, remove from air flow path to the HPU."	
			Each sensor		Check the resistance value with tester.	In case the resistance value is abnormal, replace new sensor.	
			Pump error		"1st: Push SW2 on LED panel for more than 5 seconds to enforce air-purge mode (displayed "AP") Then operate the pump automatically. 2nd: Push SW3 on LED panel for more than 5 seconds to enable monitor mode for observing the pump RPM 3rd: Push SW4 for a short time to display actual pump RPM (Check with No.17)"	"Check the number on the display is normal (between 3000 to 4000 RPM) condition: 30 to 40 = Infers PCB problem, replace PCB. Abnormal: Less than 10 (shows less than 1000 RPM) = Replace pump"	
			Expansion valve coil		Check the coil connector is properly connected.	"In case of abnormal connection, reinstall correctly. In case of defect, replace expansion valve coil"	
	PCB (Main) or HP unit		-	"Replace PCB(Main) After replacement, if the same malfunction still exists, replace HPU."			
	H8	Current transformer failure	PCB(Main)	Reset power supply.	"Replace PCB(Main) After replacement, if the same malfunction still exists replace HPU."	Power OFF	
	L5	Output over current failure	Discharge temp. sensor		Check the resistance value with tester.	In case the resistance value is abnormal, replace new discharge temp sensor.	Power OFF
			Expansion valve coil		Check the coil connector is properly connected.	"In case of abnormal connection, reinstall correctly. In case of defect, replace expansion valve coil"	
			PCB (Main) or HP unit		Check if system frequently restarts and stops – may need to reset power supply.	Replace PCB(Main) After replacement, if the same malfunction still exists, replace HPU.	
	U2	Unspecified voltage failure	Low power voltage		Check the power voltage.	Select a suitable power supply route or correct the source of abnormal voltage.	Power OFF
			Overpower voltage		Check the power voltage.	Select a suitable power supply route or correct the source of abnormal voltage.	
			PCB(Main)		Reset power supply.	"Replace PCB(Main) After replacement, if the same malfunction still exists replace HPU."	



ERROR CODES		SUSPECTED AREA OF ISSUE	INITIAL CHECKS REQUIRED	TROUBLESHOOTING	ERROR RESET	
REMOTE CONTROL	PCB					
Eg-4	HJ	"Water Circulation system failure"	"Heating water circulation circuit"	"Check there are no internal obstructions to water flow. E.g., Air ingress, contamination, or scale."	If issue persists after obstructions to water flow are cleared, reboot HPU.	Power OFF
			Each sensor	Check the resistance value with tester.	In case the resistance value is abnormal, replace new sensor.	
			Expansion valve	Check the coil connector is properly connected.	"In case of abnormal connection, reinstall correctly. In case of defect, replace expansion valve coil"	
			PCB (Main) or HP unit	-	"Replace PCB(Main) After replacement, if the same malfunction still exists , replace HPU."	
	EC	Outlet water temp. failure	"Heating water circulation circuit"	"Check there are no internal obstructions to water flow Ex; Air ingress, contamination or scale."	If issue persists after obstructions to water flow are cleared, reboot HPU.	Power OFF
			Water outlet temp. sensor	Check the resistance value with tester.	In case the resistance value is abnormal, replace new water outlet temp sensor.	
			Pump	"Feel pump to ensure it is operating".	"Replace pump if not operational or broken."	
			PCB (Main) or HP unit	-	"Replace PCB(Main) After replacement, if the same malfunction still exists replace HPU."	
	H1	Inlet water temp. failure	Water inlet temp. sensor	Check the resistance value with tester.	In case the resistance value is abnormal, replace new water inlet temp sensor.	Power OFF
				Check the sensor connector is properly connected.	"In case of abnormal connection, reinstall correctly. In case of defect, replace new water inlet temp sensor."	
			Tank temp. sensor	Check the resistance value with tester.	In case the resistance value is abnormal, replace new tank temp sensor.	
				Check the sensor connector is connected properly.	"In case of abnormal connection, reinstall correctly. In case of defect, replace new tank temp sensor."	
	v1.1 controller	Check wiring connection to the controller.	"In case of wire damage or disconnection, reinstall correctly or replace wiring. In case of V1.1 controller defect, replace."			
Eg-5	E9	Water pump failure	Pump connector	Check the sensor connector is properly connected.	"In case of abnormal connection, reinstall correctly. In case of defect, replace new sensor connector."	Power OFF
			Pump error	"1st: Push SW2 on LED panel for more than 5 seconds to enforce air-purge mode (displayed "AP") Then operate the pump automatically. 2nd: Push SW3 on LED panel for more than 5 seconds to enable monitor mode for observing the pump RPM. 3rd: Push SW4 for a short time to display actual pump RPM (Check with No.17)"	"Check the number on the display is in a normal condition: 30 to 40 (Between 3000 to 4000 RPM) = Infers PCB problem, replace PCB. Abnormal: Less than 10 (equals less than 1000 RPM) = Replace pump"	
			PCB(Main)			
			Tank	Except the above-mentioned.	After filling the storage tank, Air-Purge the system.	
Eg-6	E7	Fan motor failure	Fan motor	"Check the motor connector is properly connected. Check for any obstruction on fan blades or motor shaft."	"After ensuring the connection is properly installed and removing any obstructions, if the same malfunction still exists, replace fan-motor."	Power OFF
			PCB(Main)	Except above mentioned.	Replace PCB (Main)	
Eg-7	F3	Unit overheating failure	Discharge temp. sensor	Check the resistance value with tester.	In case the resistance value is abnormal, replace new discharge temp sensor.	Power OFF
			Expansion valve coil	Check the coil connector connection proper or poor/disconnection	"In case of abnormal connection, reinstall it correctly. In case of defect, replace expansion valve coil"	
			PCB (Main) or HP unit	Except above mentioned.	"Replace PCB(Main) After replacement, if the same malfunction still exists, replace HPU."	



Eg-8	Tank Temperature sensor not detected (open circuit)
Eg-9	Tank Temperature sensor fault (short circuit) Note: Temperature control mode is disabled for Eg-8 and Eg-9 faults, however boost mode is still operational.
Eg-10	<p>Tank has not heated to 59°C in the last 24 hours. This error will clear if the boost button is pressed or the tank heats to 59°C or more</p> <p>This error will only appear 24 hours after any of these actions:</p> <ul style="list-style-type: none">• The last sensor reading of 59°C (or more), resets the timer every time this temperature is measured• Boost button is pressed• There was a power up sequence <p>This is a good way of alerting the user if the heat pump is not heating properly</p>

3.2 HOT WATER STORAGE TANK

3.2.1 PTRV

Any system design must allow a means of pressure release at no more than 850kPa, using a PTRV. The PTRV must have a downward direction copper pipe connected that is open to the atmosphere, running the expelled hot water or air to a safe, frost free and appropriate drainage location. From time to time the PTRV may discharge small amounts of water under normal operations (1L for every 50 Liters heated). If the tank is installed indoors, a safety tray must be installed beneath the hot water tank to safely collect any water expelled from the PTRV.

Check PTRV every 6 months. Lift lever to test the manual relief. Water should emerge from the relief valve. It is recommended that the manual relief is tested every 6 months, to flush out any deposits that may accumulate under the seal.

3.2.2 ANODE

The anode on the glass lined (vitreous enamel) tanks is sacrificial; however, it is designed to protect the vitreous enamel lined cylinder in most public reticulated water supplies for five years after which time it should be checked as part of an annual service. It must be noted however that some water supplies can exhibit chemical qualities that are not suitable for the standard anode supplied with glass-lined water heater. Where the Total Dissolved Solids (TDS) is greater than 600mg/L or less than 40mg/L, the installed anode may be unsuitable for use to protect your water heater. In these circumstances, a plumber or authorized service person should be contacted to fit the correct (hard water) anode. Please note that warranty becomes void if the TDS value exceeds 2500 mg/L. Check the tank anode (for glass-lined tanks only) initially 5 years, then every 3 years, thereafter.

3.2.3 HYDROGEN BUILD UP

Glass lined (vitreous enamel) tanks are fitted with a Magnesium anode to provide corrosion protection for the tank from the storage water. Small quantities of hydrogen gas can be released by the anode, which generally, remains dissolved in the water and flushed away as hot water is used from the tank. Dependant on the water quality there may be a degree of hydrogen build-up in the tank if the water heater has not been in use for two or more weeks or if water appears milky in color. To resolve the build-up of hydrogen within the tank, "purge" the tank for approximately 30 seconds from the lever on the PTRV. Stand clear of PTRV discharge piping outlet.

WARNING

Ensure there are no open flames or ignition sources close to the tank.

3.2.4 DRAINING THE WATER HEATER

Reclaim system does not require drainage unless the system is left without power or unused for holidays or maintenance reasons. If drainage is required, the below steps must be followed:

1. Turn off the electricity supply to the water heater.
2. Turn off the cold-water supply to the water heater at the isolating valve.
3. Gently operate the lever on the PTRV to release the pressure in the water heater.
4. Disconnect the cold-water inlet union and attach a drain hose to the water heater.
5. Gently operate the easing lever on the PTR Valve to let air into the water heater and allow water to escape through the hose.

WARNING AND CAUTION

The degree of harm and damage that occur with incorrect use is categorised and explained below.



CAUTION

These are “Procedures that may lead to **minor injuries and damage** to property”.

Procedures to be followed are explained by the following graphic symbols.



PROHIBITED

Procedures (**Prohibited items**) that must not be done.



MANDATORY

Procedures (**Mandatory items**) that must be done.



WARNING



MANDATORY

- **The system contains refrigerant under very high pressure. The system must be serviced by qualified persons only.**
(Otherwise, it may cause an accident or malfunction)
- **This appliance may deliver water at a high temperature.**
Refer to the Plumbing Code of Australia (PCA), local requirements and installation instructions to determine if additional delivery temperature control is required.
(Failure to comply may cause an accident or scald injury)
- **Pipe construction directly connected to the water supply must be completed using specified piping materials by a certified plumbing contractor of your local authority (water supply manager).**
Failure to comply may cause an accident or malfunction)
- **Installation must be carried out by an accredited tradesperson; they must use the specified parts and adhere to the install manual for installation procedures.**
Failure to comply may cause fire, electric shock, and water leakages)
- **Use the dedicated earth leakage circuit breaker (RCD) on its own.**
(When used together with other devices, it may cause a fire due to heat generation)
- **Always use specified cables to connect wires. It is prohibited to connect midway or use stranded wires.**
(Non-compliance may cause a malfunction or heat generation and fire)
- **When commissioning, check the operation of the earth leakage circuit breaker (RCD).**
(In the case it is inoperative, it may cause a malfunction or electric shock)
- **Ensure unit is installed in a location that can withstand the weight of the unit when filled to capacity.**
(Falling equipment may cause accident or injury)
- **Do not install near automatic control devices such as medical equipment, automatic doors, and fire alarms etc.**
(The electric waves from automatic devices may affect the device and cause an accident due to malfunction)

 **WARNING**



- **Do not install near gas containers or flammable items.**
(Otherwise, it may cause an accident or malfunction. Installing too close to these hazards may cause malfunction, accident and/or injury)
- **Do not install the heat pump unit indoors.**
(Oxygen deficiency may occur if the refrigerant leaks)
- **Do not install the heat pump unit near balcony handrails.**
(Hazard - children climbing may cause injury)

 **CAUTION**





- **The water supplied to the system must comply with the drinking water quality standard or national water quality standards.**
(When hot spring water or well water is used, (or does not comply with this standard) it may cause malfunction or water leakages)
- **When fixing screws to the wall, make sure to fix them in a manner that ensures electrical insulation from the lath mesh in the wall.**
(If not adhered to, contact areas between the screw and lath mesh may cause fires)
- **Ensure drain construction is followed as per the install manual.**
(Not adhering to this requirement may cause flooding)
- **Construct an indirect drainage.**
(Otherwise, it may cause a water leakage due to damage of the tank and if dirty water flows backwards into the tank, it may cause harm to your health due to the change in water quality)
- **Ensure drainage to sewage outlet is water sealed to prevent sewage gas leaking**
- **(Pipes may corrode if sewage gas flows backwards, which may lead to water leaks)**
- **Prevent freezing.**
(Freezing may cause scald injuries and water leakages due to pipe damage)
- **If heat pump unit is not in use for an extended period of time before commencing use, confirm the Reclaim tank and heat pump unit are fully drained and remain empty until the system is in use.**
(If not adhered to, may cause harm to your health when consumed due to the change in water quality)



- **Do not install on floors or sites that are not waterproofed and treated for drainage.**
(Not adhering to this requirement may result in flooding)
- **Do not install it in an area accessible to small animals. (Small animals may cause smoke or ignition if entering the system and interfering with electrical parts) Small animals may enter into the device and touch the electrical parts etc. which may cause smoke or ignition)**
- **Do not touch the heat pump unit's air outlet or Aluminum fin.**
(Touching air outlet or fin may cause injury)



1300 383 815
HELLO@RECLAIMENERGY.COM.AU
RECLAIMENERGY.COM.AU

facebook.com/CO2HeatPump 
instagram.com/reclaimenergy 

20937660(K)



RECLAIM
ENERGY